

# Mellor

THE MOTOR GEAR PEOPLE



AC & DC  
Motors &  
Geared Motors

t: +44 (0) 1254 53854

[www.mellorelectrics.co.uk](http://www.mellorelectrics.co.uk)

Mellor Electrics Ltd  
Sett End Road  
Shadsworth Business Park  
Blackburn, Lancashire  
BB1 2NW

t: +44 (0) 1254 53854  
f: +44 (0) 1254 678625  
e: sales@melloelectrics.co.uk  
www.melloelectrics.co.uk



# Mellor

THE MOTOR GEAR PEOPLE



- Profile **4**
- AC Motors **5**
- DC Motors **6**
- T2 AC Geared Motor **7**
- T3 AC, T11 AC Geared Motors **8**
- T3 AC, T11 AC Geared Motors **9**
- T3 DC, T3 Brushless DC, T11 DC Geared Motors **10**
- T4 AC, T4 DC Geared Motors **11**
- T5 DC Geared Motors **12**
- T6 AC Geared Motors **13**
- T6 DC Geared Motors **14**
- T7 AC Geared Motors **15**
- T10 DC Geared Motors **16**
- T14 AC Geared Motors **17**
- Fans **18**
- Distributors **19**

## About Us

As one of the world's leading motor/gearbox manufacturers, Mellor Electrics deals with companies as far afield as North America, Australia and Japan. It is vital our product remains reliable, consistent and accurate throughout its working life. To achieve this goal we keep the majority of our processes in-house, thereby maintaining total control of all aspects of production. Our CNC turning and hobbing machines offer levels of accuracy which, when combined with our CAD facilities and computerised testing equipment, allow us to offer unrivalled quality and service.

Originally founded in 1964, Mellor Electrics has constantly grown and evolved to meet the needs of the customer. Extensive investment in human resources and modern machinery has enabled us to offer flexibility in all areas of our business. We operate from a custom built, 2600 square metre factory which affords us the space we need to offer stock holding and kanban facilities to our customers.

With approval to BS EN ISO9001:2008 and as a UL recognised manufacturer, we pride ourselves on our ability to meet customer requirements and exceed expectations.



## The Products

The Mellor Electrics range comprises of the SC9 Asynchronous Shaded Pole, FRS Brushed Permanent Magnet and BD Brushless DC motors that can be fitted to our range of gearboxes. Our products are suitable for a vast array of applications and have so far been used in vending machines, pellet burning stoves, pumps, catering equipment, animated displays, scientific equipment and other applications too numerous to mention.

All our motor gearbox units are lubricated for life and many features such as shaft length and diameter can be modified to suit each application. Our in-house design and engineering facilities allow us to tailor our product to your needs and we are happy to discuss any special requirements with the customer.

## SC9 AC Series Motors

At the heart of the Mellor Electrics AC range is the SC9 single phase asynchronous shaded pole motor, the motive power for our AC motor/gearboxes. Also available as a motor only unit, this dependable and consistent performer offers long life, low cost and quiet running.

- Available in six stator heights  
13mm - 50mm
- Lubricated for life
- Sintered or ball-race bearings
- 6mm diameter precision ground steel shaft (stainless steel available)
- Voltage range 24v to 415v AC  
- Insulation to class B as standard, Class F & Class H available
- Impedance, re-setting or non re-setting thermal protection
- 6.35mm male tab, flying lead terminations, or bespoke harnesses available

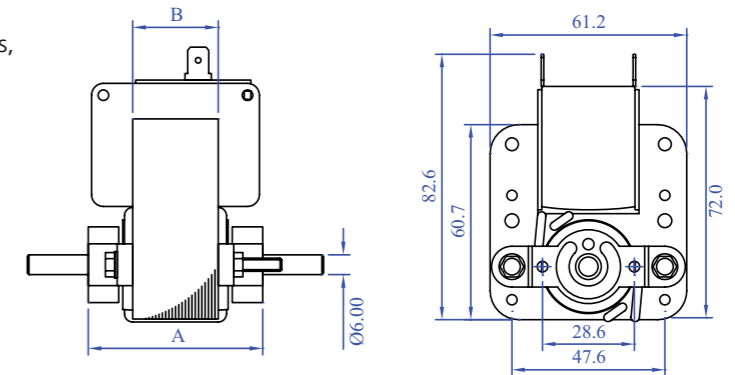
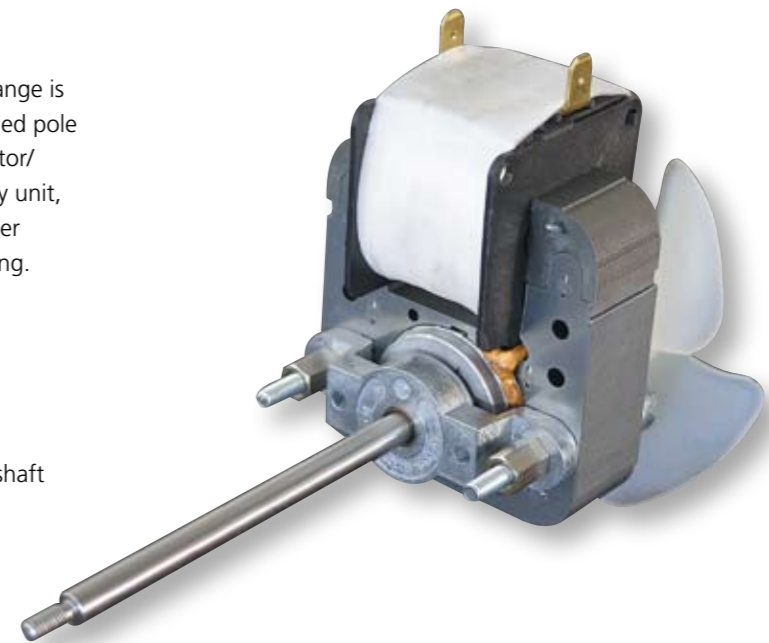

### SC9 SERIES MOTORS

Cat no.	A	B	Weight (kg)	Rating	Starting Torque	Torque kg/cm	Input watts
SC9 50	41	13	0.45	CONT. INT.	74 90	83 140	15 30
SC9 75	47	19	0.624	CONT. INT.	106 140	125 245	19 38
SC9 100	54	26	0.794	CONT. INT.	136 260	168 340	24 48
SC9 125	60	32	0.964	CONT. INT.	170 323	208 400	30 60
SC9 150	66	38	1.14	CONT. INT.	205 390	240 475	35 70
SC9 200	79	51	1.39	CONT. INT.	250 470	290 560	60 120

## FRS DC Series Motors

The FRS series of DC permanent magnet field motors are available in three can sizes, 3, 5 & 7 series, 12 or 24 volts and a variety of speeds. These efficient, high quality motors are suitable for continuous operation and can be supplied on their own or fitted with a wide range of gear boxes.

- Carbon brushes
- Hardened steel shaft
- Lubricated for life sintered bearings
- Life up to 3000 hrs - depending on usage
- Terminated to solder tabs, connection PCB or flying leads
- Fitted with internal suppression to meet EMC directives

## FRSW Series

Designed as a cost-effective replacement for bulky AC vending whipper motors, the FRSW series is available with a wide range of stainless steel shafts. Speeds of 10,000, 12,500, 14,000 and 17,000rpm are standard, as are connector PCBs or flying leads and an adaptor that allows direct connection to currently available whipper chambers.

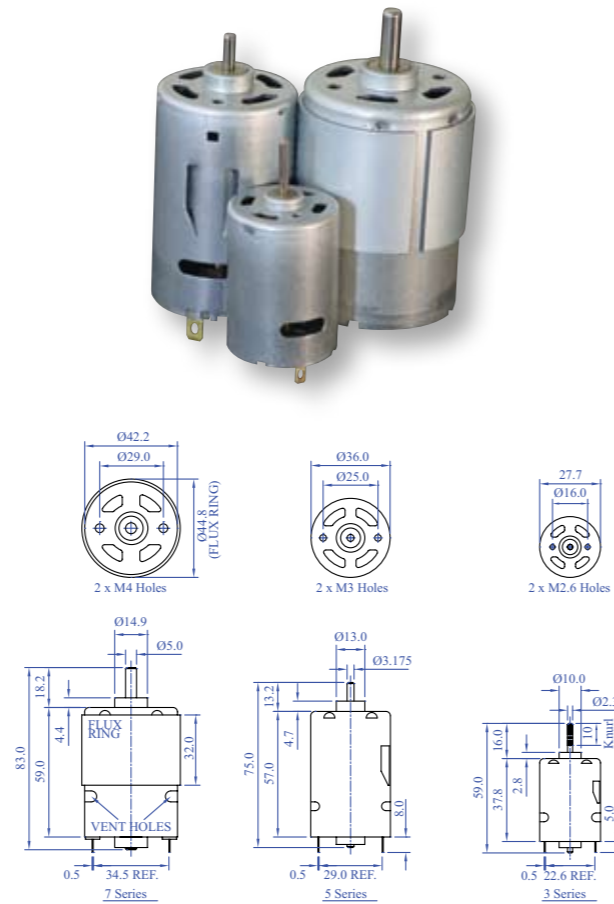

FRS/FRSW DC MOTORS							
Cat no.	A	B	C(Ø)	D(Ø)	E(Ø)	F	Screw Holes
FRS-380	37.8	59	27.7	10	2.3	16	M2.6
FRS-545	50	72	35.8	13	3.175	25	M3
FRS-555	57	75	36	13	3.175	25	M3
FRS-700	59	83	44.8	14.9	5	29	M4

## EB - T2 AC Series Geared Motor Units

A compact and versatile unit, the EBT2 is available in a variety of configurations and can be supplied with sintered bronze or ball race output bearings. As a lower cost option we also offer this unit with a moulded plastic gear-train and a plastic output shaft design to mate with a variety of vending canister systems.

- Available with an AC SC9 motor
- Output Torque: Up to 4Nm depending on speed and motor size
- Speed Range: 20 to 325rpm

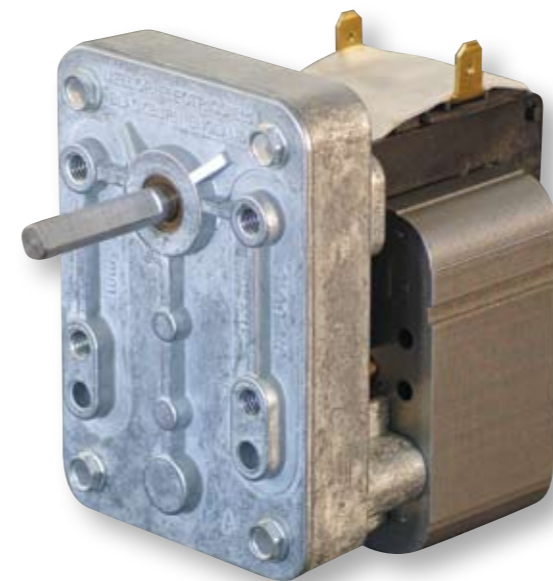

Lower Cost Option

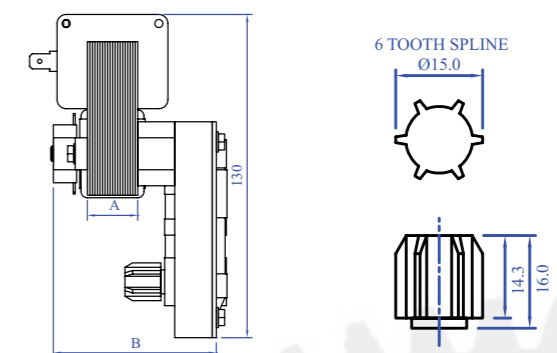
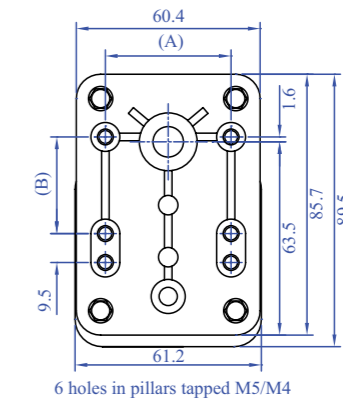
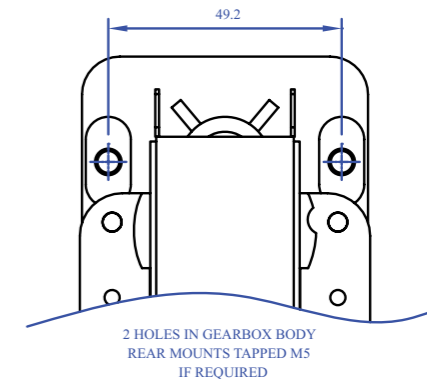
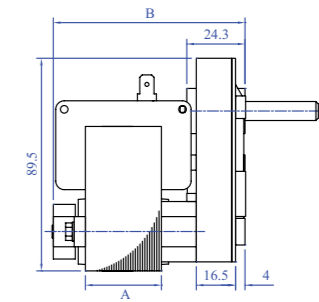
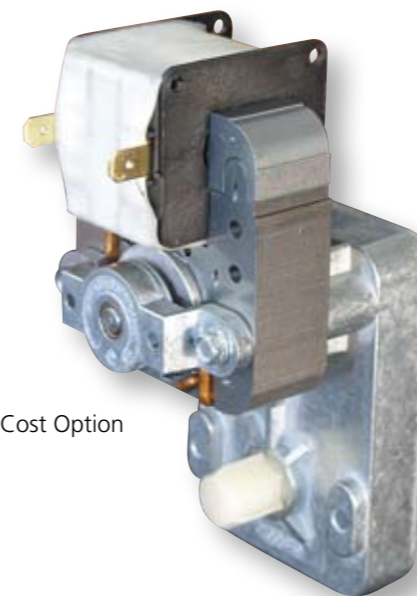

EB T2 SERIES MOTORS		
Cat no.	A	B
EBS/EBL50 T2	13	62
EBS/EBL75 T2	19	68
EBS/EBL100 T2	26	74
EBS/EBL125 T2	32	81
EBS/EBL150 T2	38	87

## FB / FBD / FBBD T3 Series Geared Motor Units

The heavyweight of our range, the FBT3 is a low speed, high torque unit designed with pellet fired appliances and fresh brew vending systems in mind, although it is equally suited for many other applications. High quality engineering ensures a quiet and long running life. Available with SC9 AC, Synchronous AC, DC and Brushless DC versions to suit a wide range of applications. Output shaft length and diameter to suit individual customer requirements.

### FB - T3 AC Series

- Available in 5 motor sizes (19mm - 50mm)
- Output Torque: Up to 35Nm, depending on speed and motor size
- Speed Range: 0.8 - 50rpm

FB T3 SERIES MOTORS		
Cat no.	A	B
FBS/FBL75 T3	19	84
FBS/FBL100 T3	26	91
FBS/FBL125 T3	32	97
FBS/FBL150 T3	38	103
FBS/FBL200 T3	51	116

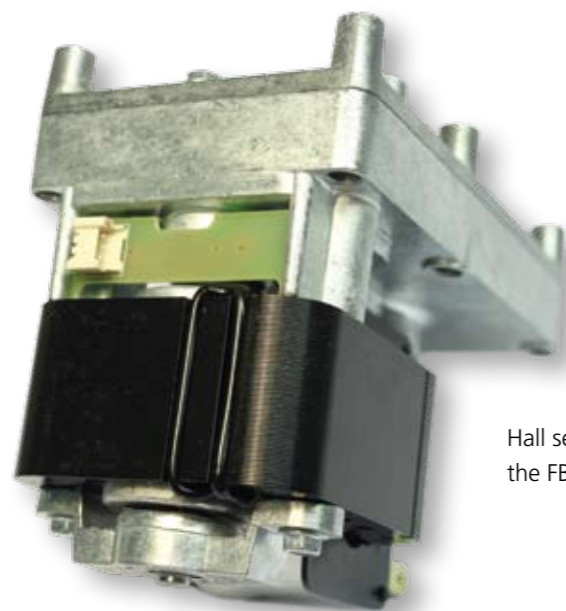
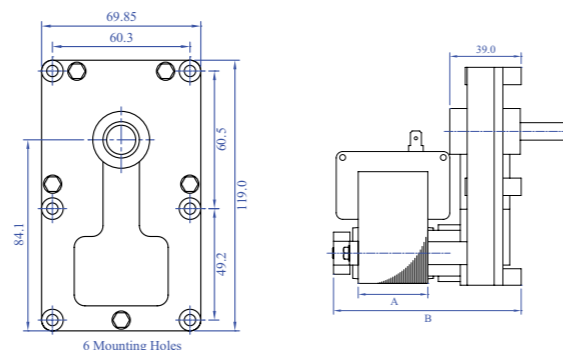
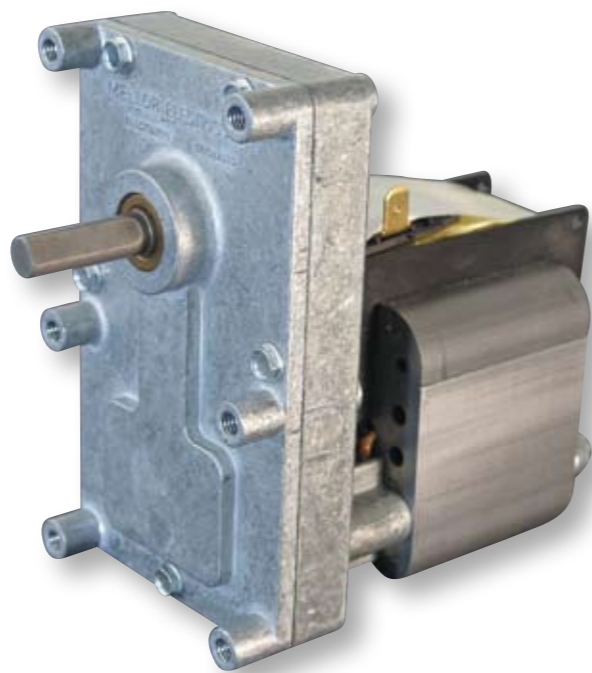

Hall sensor available for the FBT3 with 4ppr

## HT / HTD T11 Series High Torque Units

The FB T3 can be fitted with an additional external gearbox. This produces a unit that can give extremely slow rpm and very high torque.

- Available in AC (HT) and DC (HTD) versions
- Output Torque: Up to 50Nm depending on speed and motor size
- Speed Range: 0.35 - 22rpm AC / 1.5 - 22rpm DC

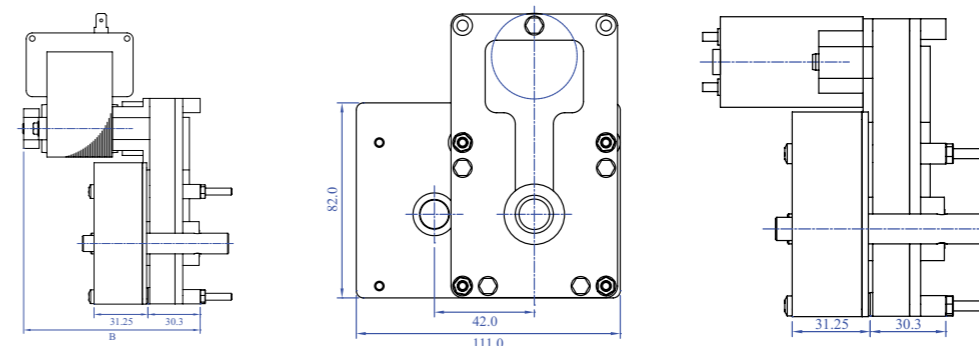
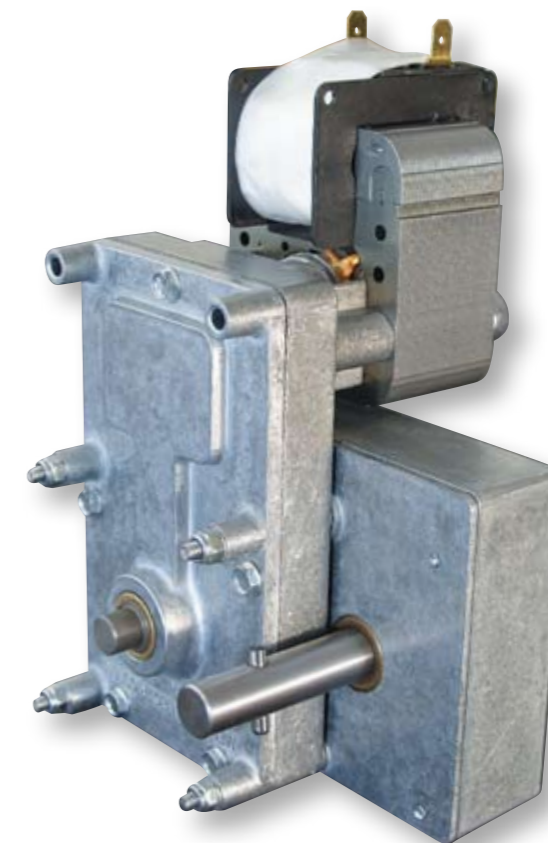

HT T11 SERIES MOTORS		
Cat no.	A	B
HTS75 T11	19	84
HTS100 T11	26	91
HTS125 T11	32	97
HTS150 T11	38	103
HTS200 T11	51	116

## FBD - T3 DC Series

- Available with a 5 or 7 series FRS-DC motor
- Output Torque: Up to 35Nm depending on speed and motor size
- Speed range: 3.5 - 50rpm

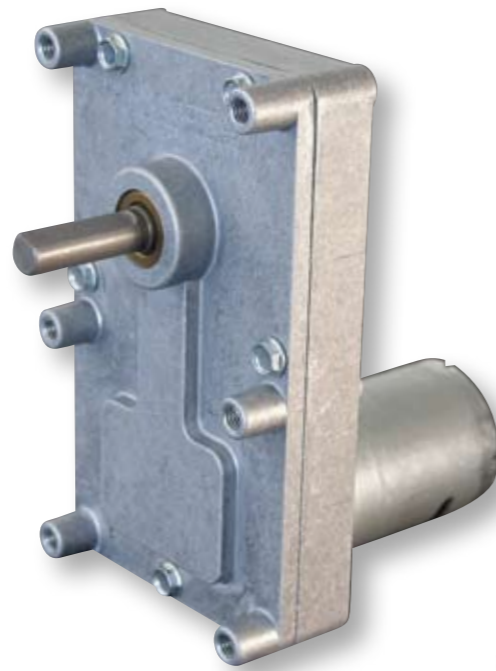
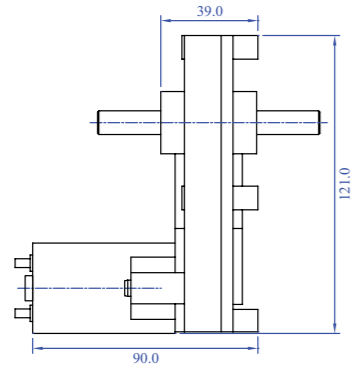

## FBNB - T3 DC Brushless Series

24VDC Brushless DC motor to suit many applications. Reversible and with the ability to speed control as standard features. Designed for silent running to suit noise sensitive environments. High quality engineering ensures long running life.

- 24V DC motor speed 2945rpm
- Speed range (gearbox) 1-50rpm
- Rated motor wattage: Input - 14.5w, Output - 7.5w
- Outer rotor construction
- Analogue Speed Control 0-5VDC
- CCW/CW
- Encoder output 5PPR
- Output torque: up to 35Nm depending on speed
- Maximum operating temperature 50°C

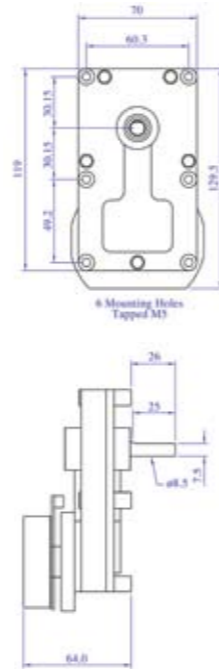
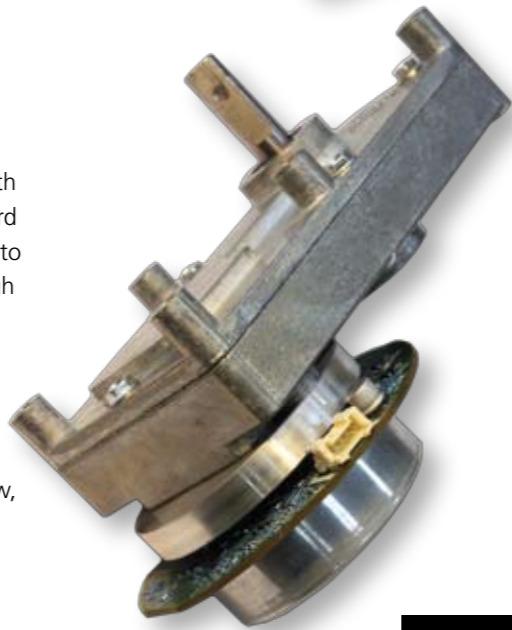

**FBNB BLDC SERIES MOTOR**  
(Figures based on 24VDC - 5V input & 0.51 amps limit)

RPM	Torque (Nm)
20	3.5
10	6.8
3	23
2	34

## FBBD - T3 DC Brushless Series

- Output Torque: Up to 35Nm depending on speed
- Output Speed range: 0 - 50rpm
- Optional integrated electronic drive card

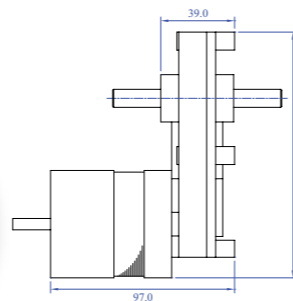
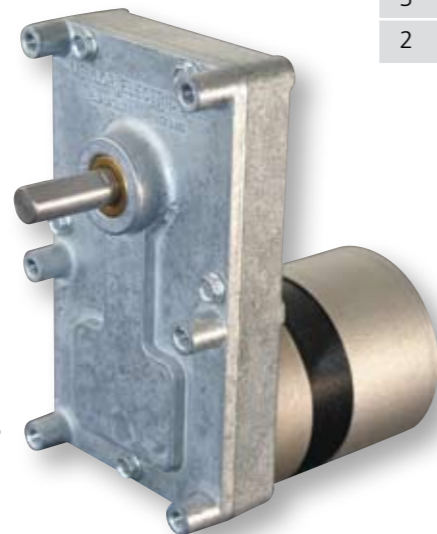

## CB/CBD T4 Series Geared Motor Units

Used extensively in chemical pumping and dosing applications, the CBT4 has a compact design which makes it ideal for mounting inside small enclosures.

- Available with an AC SC9 motor in 5 stator stack sizes
- Available with a 5 series DC motor (see FRSDC section for details)
- Output Torque: Up to 4Nm depending on speed and motor size
- Speed Range: 30 to 325rpm

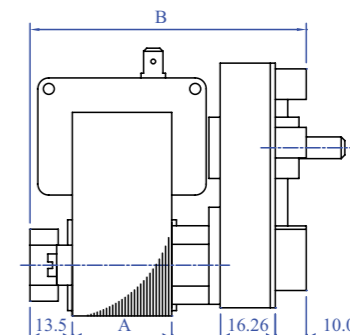
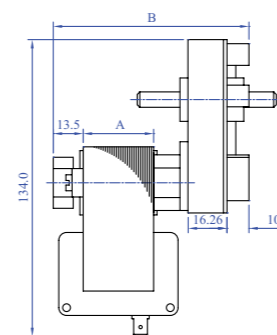
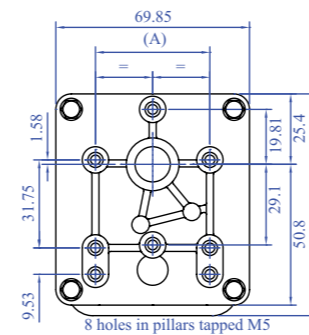
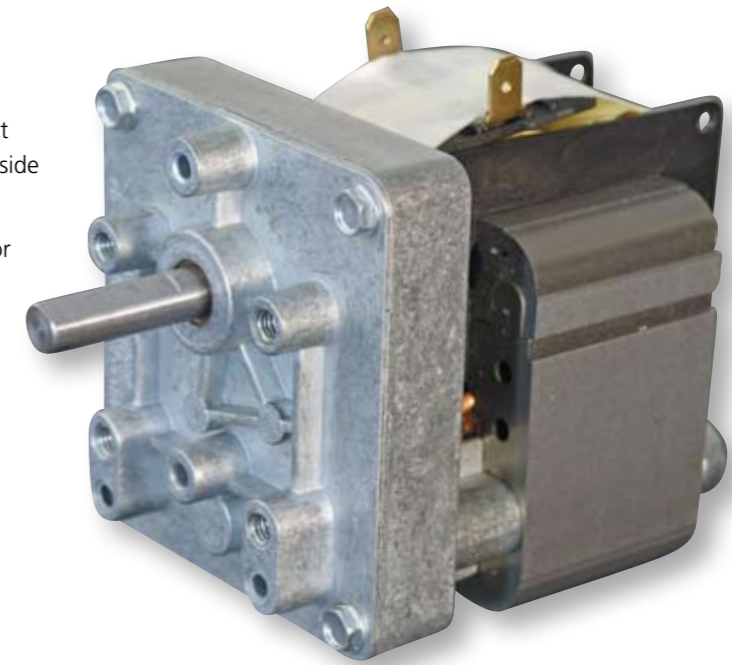

## CBD - T4 DC Series

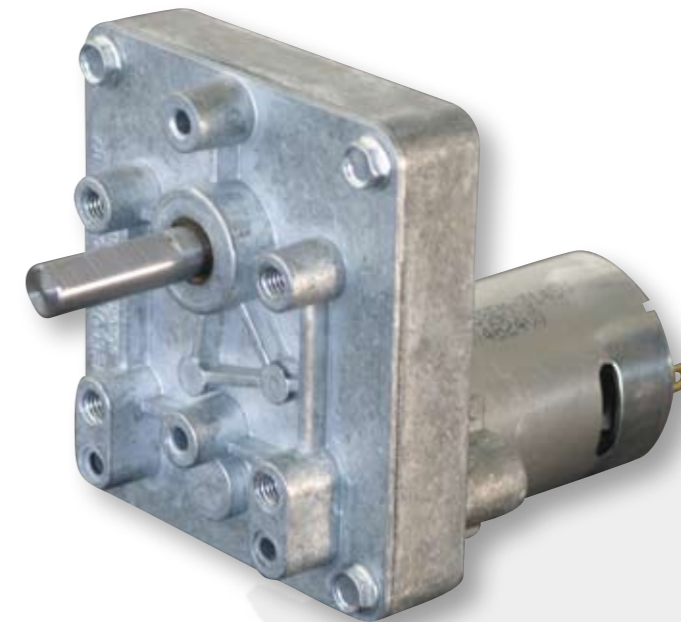
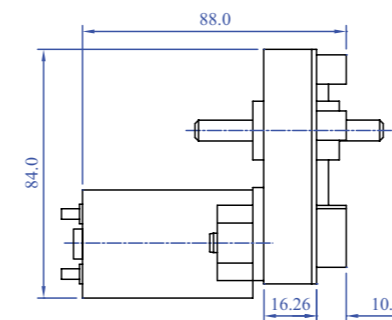

## CB T4 SERIES MOTORS

Cat no.	A	B
CBS/CBL50 T4	13	70
CBS/CBL75 T4	19	76
CBS/CBL100 T4	26	83
CBS/CBL125 T4	32	89
CBS/CBL150 T4	38	95

## GBD - T5 DC Series Geared Motor Units

This versatile plastic bodied motor gearbox is slim-line and lightweight. Designed with the product engineer in mind, this unit is ideal for applications where space is at a premium but quality cannot be compromised.

- Available with a 3 or 5 series DC motor (see FRS DC section for details)
- Output Torque: Up to 2Nm depending on speed and motor size
- Speed Range: 50 to 325rpm

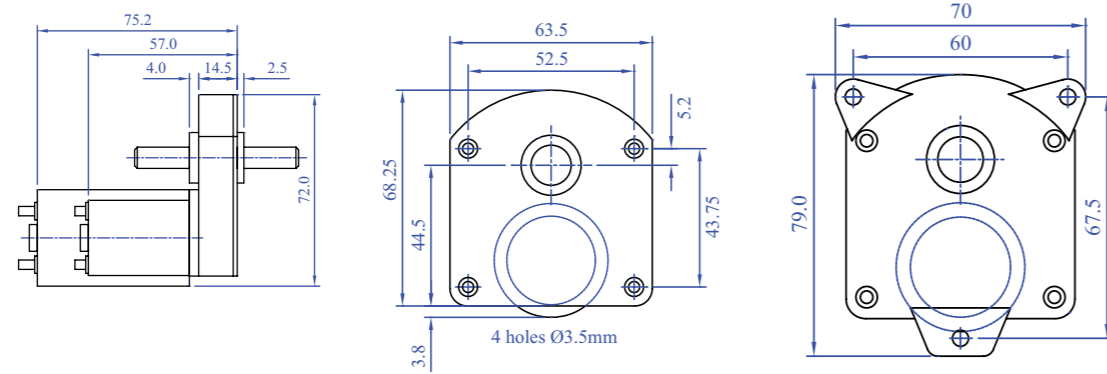
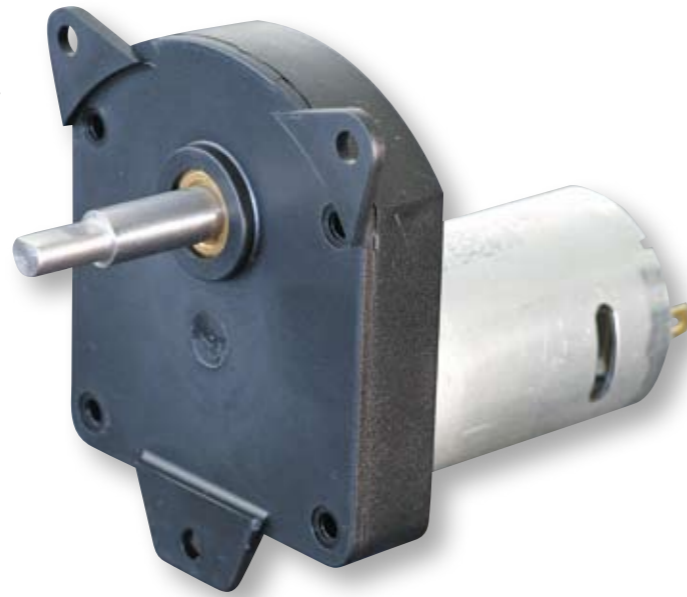

## UB/UBD/UBBD T6 Series Geared Motor Units

Our most versatile offering, the UBT6 series is available with four different lid options to suit a wide range of mountings. Used extensively in pumps, vending machines and animated displays, this unit is the perfect solution for any application that requires a quiet, robust and reliable gearbox. Available with SC9 AC, Synchronous AC, DC and Brushless DC versions. Output shaft length and diameter to suit individual customer requirements.

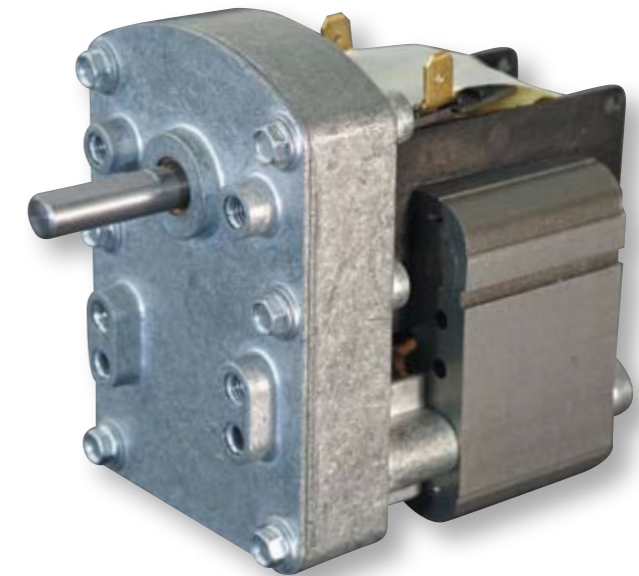

### UB - T6 AC Series

- Available with an AC SC9 motor in 6 stator stack sizes
- Output Torque: Up to 8Nm depending on speed and motor size
- Speed Range: 2.4 - 290rpm

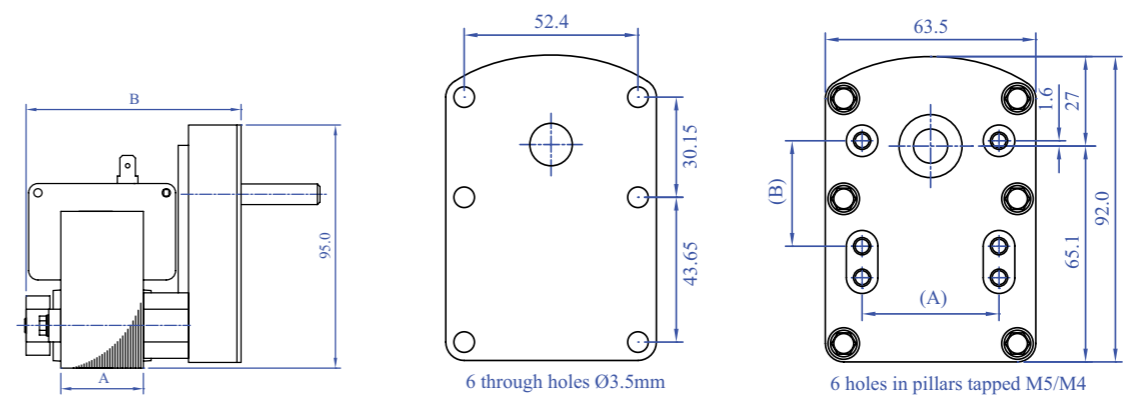

### UB T6 SERIES MOTORS

Cat no.	A	B
UBS/UBL50 T6	13	65
UBS/UBL75 T6	19	71
UBS/UBL100 T6	26	78
UBS/UBL125 T6	32	84
UBS/UBL150 T6	38	90
UBS/UBL200 T6	51	103

## UBD - T6 DC Series

- Available with a 5 or 7 series DC motor (see FRSDC section for details)
- Output Torque: Up to 8Nm depending on speed and motor size
- Speed range: 4 - 425rpm

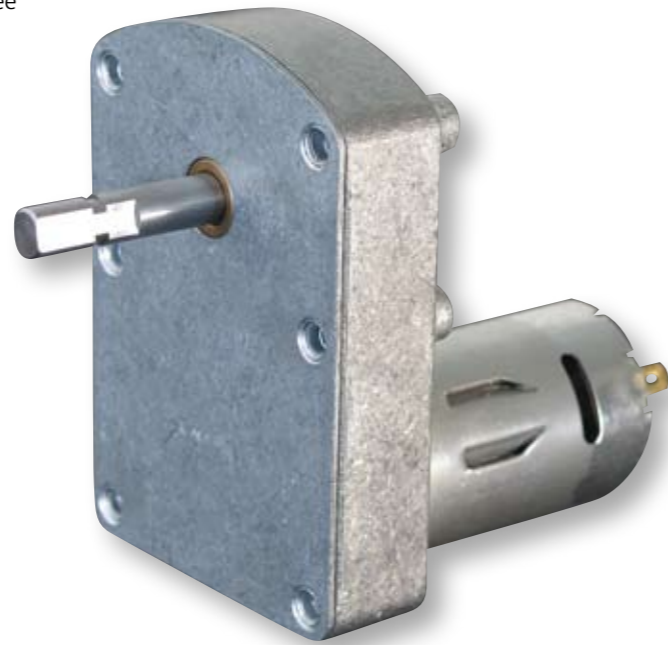
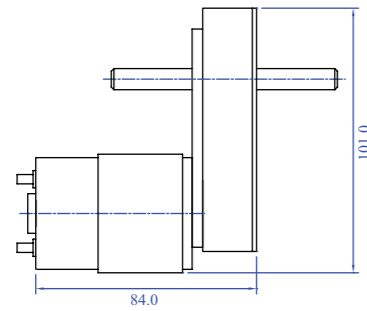
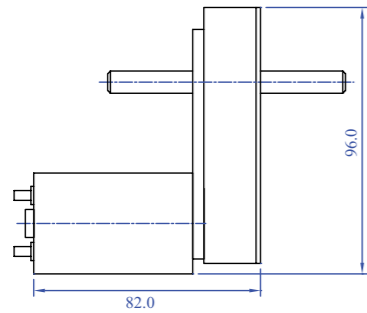

## JB - T7 AC Series Geared Motor Units

This geared motor unit was specifically designed for use with canister dispensing systems. The output is a 14.7mm diameter 18 tooth spline which will mesh with all the popular makes of ingredient canisters. The final drive gear is an integral moulding with the output spline which rotates on a ground steel shaft thus negating the need for bearings and providing long life and quiet, reliable operation. The speeds offered are limited to 80 and 140rpm, this enables us to produce the unit at a very competitive price.

- Available with an AC SC9 motor in 5 stator stack sizes
- Output Torque: Up to 1Nm depending on speed and motor size

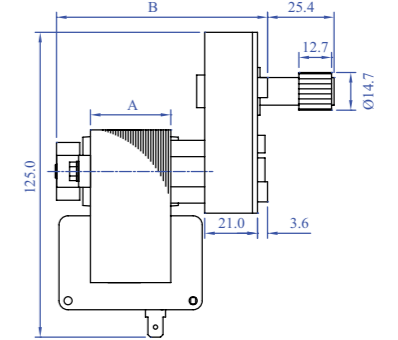
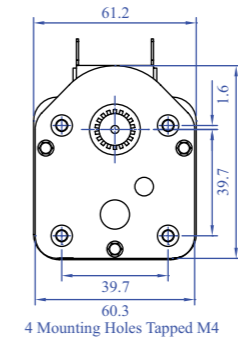
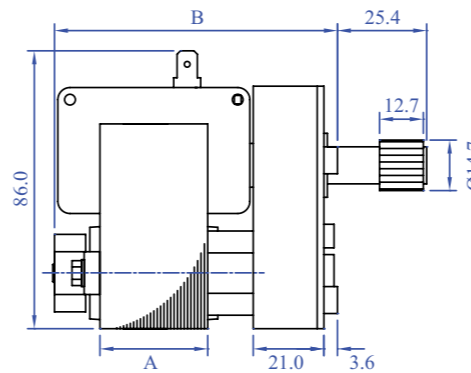
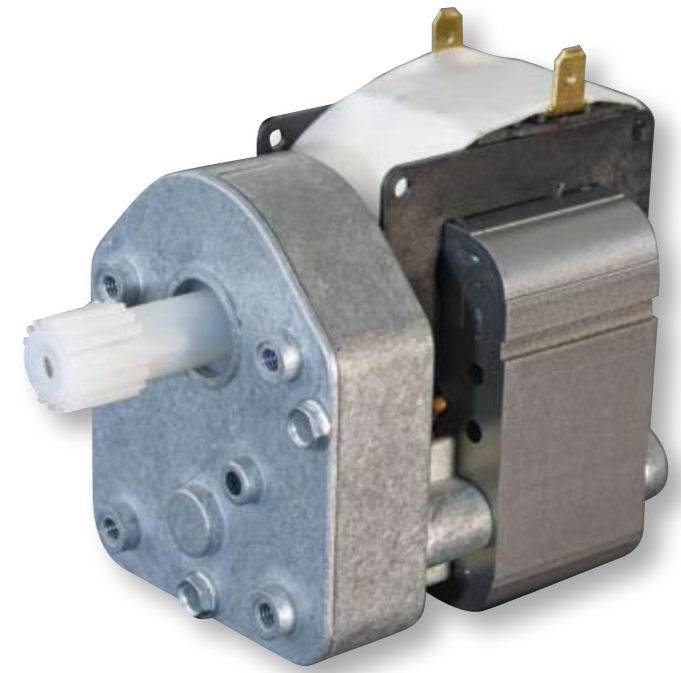

### JB T7 SERIES MOTORS

Cat no.	A	B
JBL50 T7	13	64
JBL75 T7	19	70
JBL100 T7	26	77
JBL125 T7	32	83
JBL150 T7	38	89



## MB - T10 DC Series Geared Motor Units

Featuring moulded plastic gears and housing, the MBT10 series unit provides a low cost alternative to standard metal motor gearboxes. The system has been designed on a modular basis to provide maximum versatility - two motors for different torques, choice of gears for three ratios and three different hex plug-in output shafts which can be front or rear mounted.

- Available with a 3 or 5 series DC motor (see FRS DC section for details)
- Output Torque: Up to 1Nm depending on speed and motor size
- Speed Range: 80, 120, 140 or 160rpm

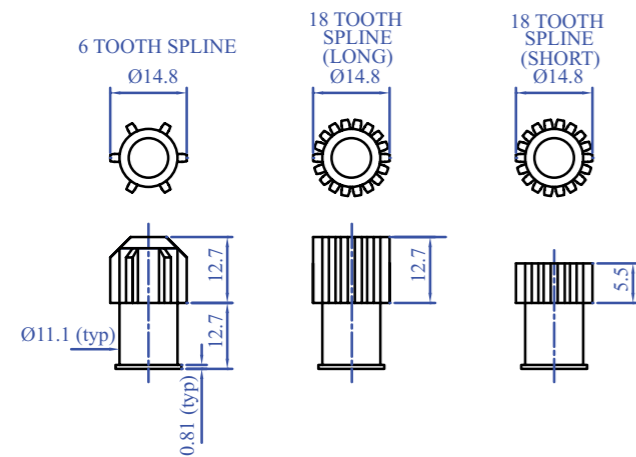
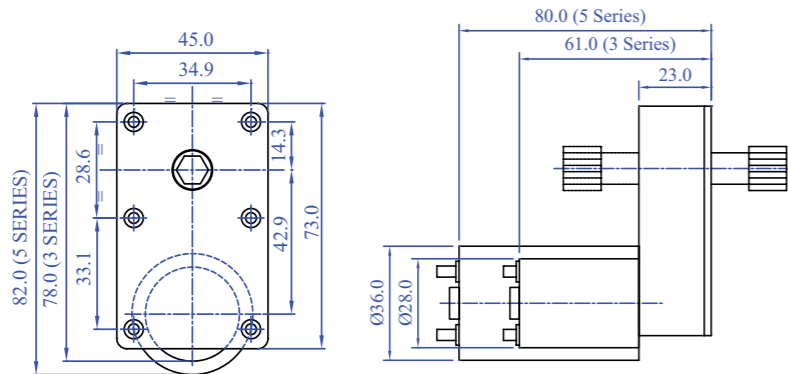

## KB - T14 AC Series Geared Motor Units

This geared motor was originally designed to complement our range between the FBT3 and UBT6. Designed with a slimline gearbox but with high torque capability allowing this unit to be used in many applications where space is limited but a high torque is required. Typical applications include pellet stoves, vending and actuation.

- Available with an AC SC9 motor in 6 stator stack sizes
- Output Torque: Up to 20Nm depending on motor size
- Hollow output wheel for interchangeable shafts
- Speed Range: 5rpm, 8rpm and 9.5rpm

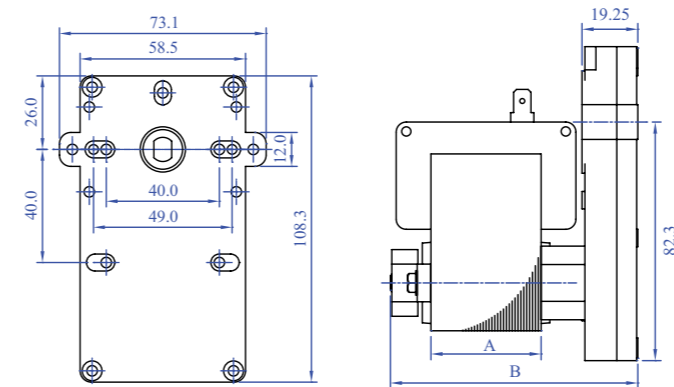

### KB T14 SERIES MOTORS

Cat no.	A	B
KBL50 T14	13	60
KBL75 T14	19	66
KBL100 T14	26	73
KBL125 T14	32	79
KBL150 T14	38	85
KBL200 T14	51	98



Part No.	Dia	Bore
RO-2039	1 3/4"	3/16"
RO-2040	1 3/4"	6mm

Clockwise



Part No.	Dia	Bore
RO-2028	1 3/4"	3/16"
RO-2029	1 3/4"	6mm

Counter Clockwise



Part No.	Dia	Bore
RO-2035	2 1/16"	3/16"
RO-2037	2 1/16"	6mm

Clockwise



Part No.	Dia	Bore
RO-2036	2 1/16"	3/16"
RO-2038	2 1/16"	6mm

Counter Clockwise



Part No.	Dia	Bore
RO-2020	3"	3/16"
RO-2022	3"	6mm
RO-2024	3"	1/4"

Clockwise



Part No.	Dia	Bore
RO-2021	3"	3/16"
RO-2023	3"	6mm
RO-2026	3"	1/4"

Counter Clockwise



Softing Italia Srl  
ITALY & EASTERN EUROPE

t: + 39 02 45 05 171  
www.softingitalia.it



DENMARK

t: +46 75-242 44 00  
e: info@motor.oem.se  
www.oem-motor.se



t: +44 (0)1367 711900  
e: sales@abbeychart.co.uk  
www.abbeychart.co.uk



FRANCE

t: +33 1 43 57 65 29  
e: commercial@salina.fr  
www.salina.fr



PORTUGAL

t: +351 22 961 80 90  
e: geral@reiman.pt  
www.reiman.pt



SWEDEN

t: 075-242 44 00  
e: info@motor.oem.se  
www.oem-motor.se

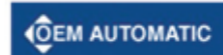

UK

t: +44 (0) 116 284 9900  
e: information@uk.oem.se  
www.oem.co.uk



UK

t: 0845 850 9900  
e: general@rs-components.com  
www.rswww.com



GERMANY

t: +49 2157 128990  
e: info@dynetics.eu  
www.dynetics.de



CANADA

t: 905 831 3311  
www.alltemp.ca



FINLAND

t: +358 207 499 499  
e: info@oem.fi  
www.oem.fi

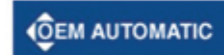

POLAND

t: +48 022 863 27 22  
e: info@pl.oem.se  
www.oemautomatic.com.pl



SPAIN

t: (+34)902.450.160  
e: bcn@ermec.com  
www.ermec.com



HOLLAND

t: +31 499371007  
e: info@dynetics.eu  
www.dynetics.nl