

4

3

2

1

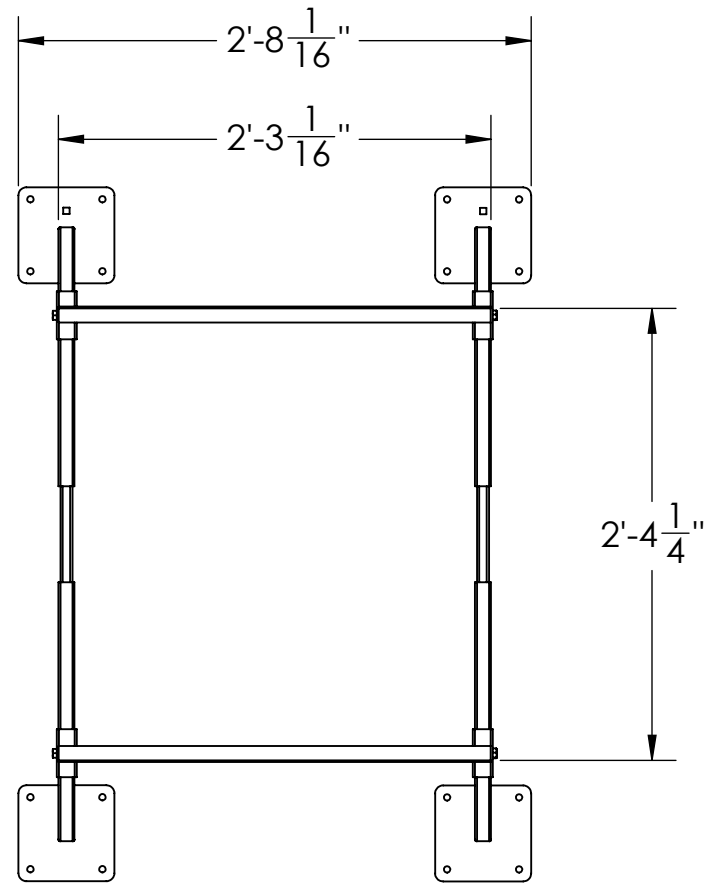

PLAN VIEW EXPANDED

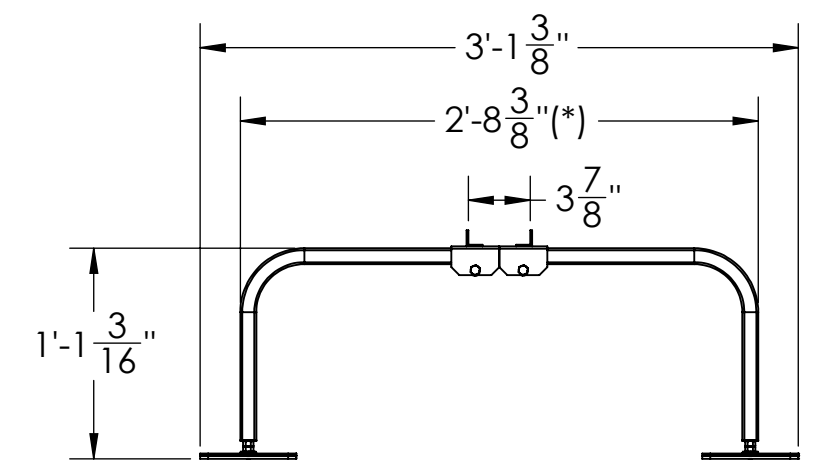

END VIEW RETRACTED

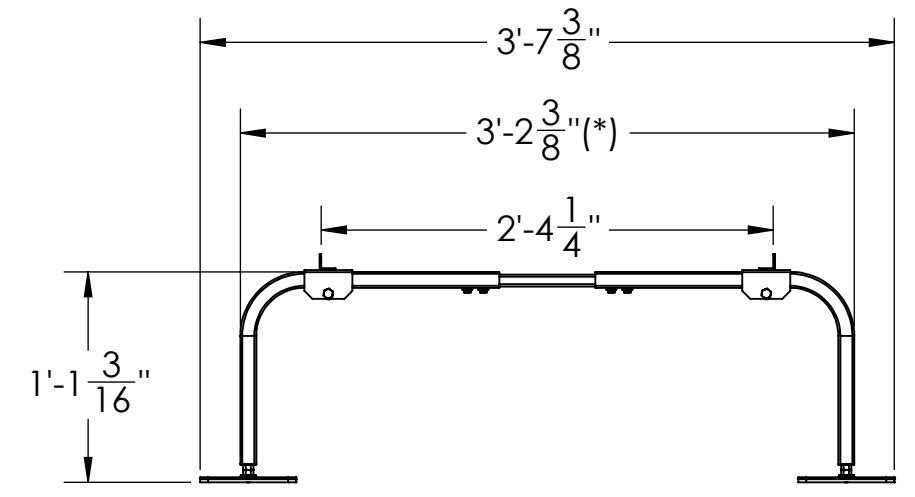

END VIEW EXPANDED

(*) - STAND WIDTH IS ADJUSTABLE IN 1" INCREMENTS

IMPORTANT NOTE: THE INSTALLER IS RESPONSIBLE FOR THETHERING AND BOLTING UNITS TO WITHSTAND WIND AND/OR SEISMIC LOADS.

UNLESS OTHERWISE SPECIFIED:
 DIMENSIONS ARE IN INCHES [MILLIMETERS]
 TOLERANCES ARE: ANGLES ±1.0°
 FRACTIONAL SIZES X/Y ±1/64

INCHES	[MILLIMETERS]
X = ±0.1	[X = ± 2.5]
.XX = ±0.01	[.X = ± 1.3]
.XXX = ±0.005	[.XX = ±0.13]

THIRD ANGLE PROJECTION



CONFIDENTIAL - PROPRIETARY - DO NOT COPY
 THE INFORMATION SET FORTH IN THIS DOCUMENT AND RELATED INFORMATION IS THE CONFIDENTIAL PROPERTY OF DIVERSITECH CORPORATION, AND IS NOT TO BE COPIED OR REPRODUCED OR DISTRIBUTED IN ANY FORM WITHOUT PRIOR WRITTEN PERMISSION FROM DIVERSITECH CORPORATION.
DO NOT SCALE DRAWING

MATERIAL:
 DWG. NO. **QUICK SLING STAND - 4002**
 MODEL NO. QSTD4002

WEIGHT
GMS.
 REV.
 SHEET
1 OF 2

4

3

2

1

B

B

A

A

ITEM NO.	PART NUMBER	DESCRIPTION	Default/ QTY.
1	MNT-A10-02-288	Angle Iron Stand 12 J-Bar	4
2	MNT-A10-03-286	Angle Iron Stand Extension Bar	2
3	MNT-A10-02-289	Iron Stand 27in Angle Iron Arm	2
4	QSR008	1/4-20x1 1/2in Zinc Hex Bolts	8
5	QSR015	1/4in Bonded Washers	8
6	MNT-A10-03-285	Angle Iron Stand 6x6 Feet	4
7	MNT-A10-04-283	6x1.5 - Mini Split Rubber Foot	8
8	QSR021	3/8-16x2in Carriage Bolt Zinc	4
9	QSR035	3/8in Bonded Washer	4
10	QSR026	3/8in Zinc Hex Nut	8
11	QSR017	3/8-16x1 3/4in Hex Bolt Galv	4
12	QSR034	3/8in Split Washer Galv	4
13	QSR025	3/8in Galvanized Hex Nuts	4

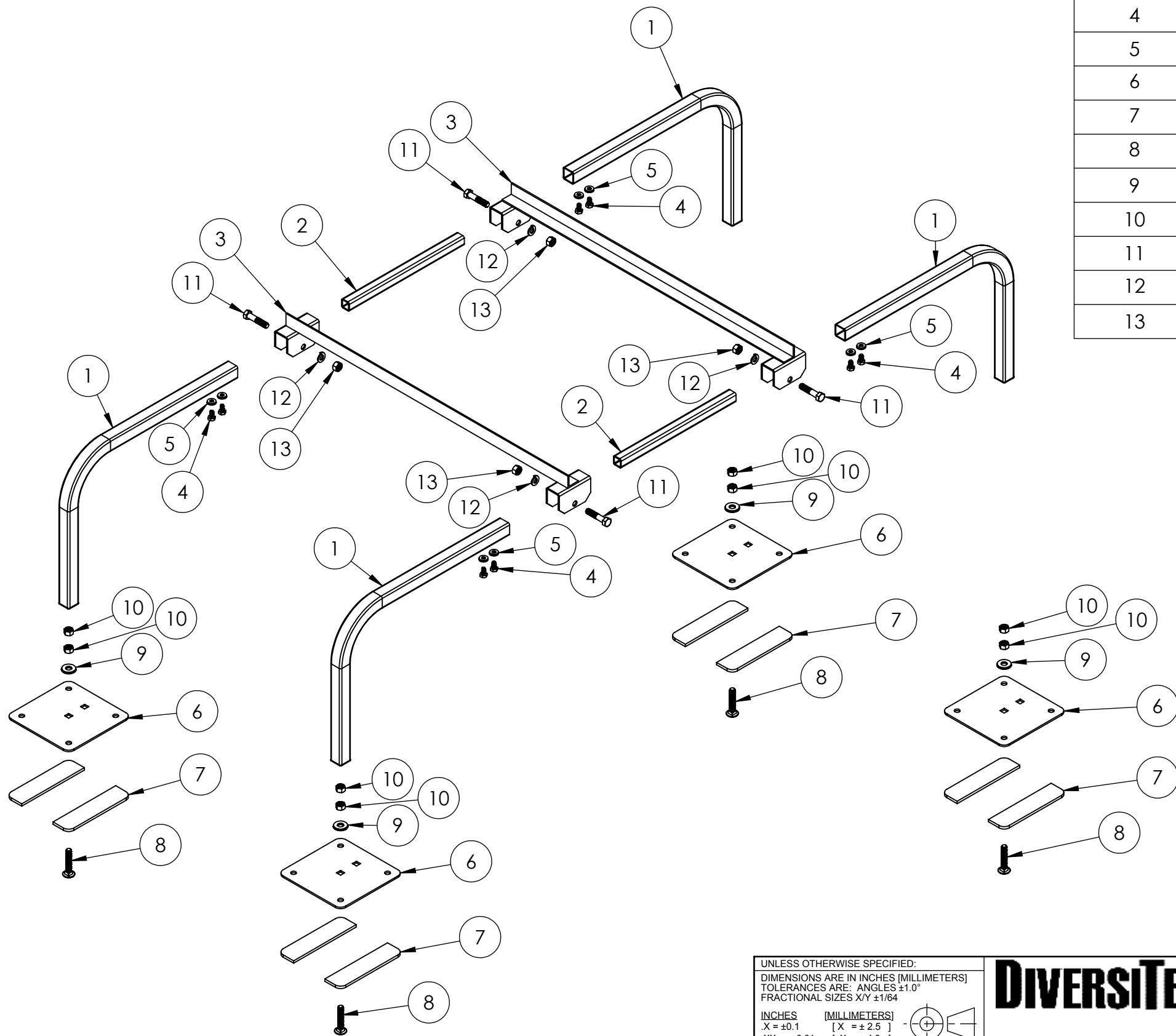

NOTE - ALL ASSEMBLY HARDWARE IS INCLUDED

UNLESS OTHERWISE SPECIFIED:
 DIMENSIONS ARE IN INCHES [MILLIMETERS]
 TOLERANCES ARE: ANGLES ±1.0°
 FRACTIONAL SIZES X/Y ±1/64

INCHES	[MILLIMETERS]
X = ±0.1	[X = ± 2.5]
.XX = ±0.01	[.X = ± 1.3]
.XXX = ±0.005	[.XX = ±0.13]

THIRD ANGLE PROJECTION



CONFIDENTIAL - PROPRIETARY - DO NOT COPY THE INFORMATION SET FORTH IN THIS DOCUMENT AND RELATED INFORMATION IS THE CONFIDENTIAL PROPERTY OF DIVERSITECH CORPORATION, AND IS NOT TO BE COPIED OR REPRODUCED OR DISTRIBUTED IN ANY FORM WITHOUT PRIOR WRITTEN PERMISSION FROM DIVERSITECH CORPORATION. DO NOT SCALE DRAWING	MATERIAL: DWG. NO. QUICK SLING STAND - 4002 MODEL NO. QSTD4002	WEIGHT GMS. REV.
	DESCRIPTION	SHEET 2 OF 2