

## Conversion Recommendations And Procedures

Change from CFC and HCFC to HFC refrigerants may cause a retraction in the o-rings and elastomers. Be sure to repair or replace after recovery of the original refrigerant. Failure to address this at this time may cause unnecessary loss of refrigerant.

ALLTEMP® recommends verification of the metering device sizing with the distributor or manufacturer of the device.

### 1) RECORD SYSTEM PRE-CONVERSION DATA:

Prior to converting, the system should be monitored and all system and component operating conditions recorded for future reference. (SEE FORM ON REVERSE SIDE)

### 2) RECOVER:

100% of the refrigerant must be recovered from system in accordance with all EPA guidelines. \*Recording the weight of the refrigerant you recover will assist you in determining the amount of R417C necessary for the conversion.

### 3) PERFORM OIL ANALYSIS:

Check system oil for acidity, water and solids (metal shavings). If detected perform a complete system oil change using the OEM specified type and amount of oil.

### 4) INSTALL NEW FILTER DRIER AND OIL FILTER:

The oil analysis will tell you what type of filter drier you need to use. Systems with coalescent oil separators and/or compressor oil filters need to be changed, too.

### 5) LEAK CHECK SYSTEM:

Pressure test system with dry nitrogen. DO NOT exceed the equipment's design pressure. R417C can be detected with any standard form of leak detection designed to detect HFC refrigerants.

### 6) EVACUATE SYSTEM:

To remove non-condensables and moisture in the system, a minimum 500 micron vacuum must be achieved.

### 7) CHARGE SYSTEM:

Remove LIQUID ONLY from R417C cylinder. When initially charging system, R417C can be added directly into the receiver tank or high-pressure side of the system with compressor off. Charge ratios for R417C may vary depending on system design and application. The initial charge of R417C should be 80% of the original R-12 charge.

### 8) RUN SYSTEM:

Check pressures, subcooling, and superheat temperatures. Use R417C P/T chart on reverse side. If additional R417C needs to be added, do so in 5% increments and DO NOT exceed 115% of the original charge of R-12. If system performance is inadequate, call TECH 2 TECH for support at 866-433-TECH(8324).

### 9) PROPERLY LABEL SYSTEM:

Avoid mixing refrigerants by properly labeling your system. For R417C system ID labels, call TECH 2 TECH for support at 866-433-TECH(8324)

### 10) POST CONVERSION LEAK CHECK:

After operation of system begins, do a thorough system leak check.

### 11) RECORD SYSTEM POST CONVERSION DATA:

Monitor and evaluate system performance and record data. This information can be compared to your preconversion data for a full conversion evaluation and can be used if further technical support is required.

## REMEMBER WHEN CONVERTING OR RETROFITTING DID YOU.....?

- Adjust your low pressure control, evaporator or crankcase pressure regulator to the corresponding P/T relationship.
- Confirm the fan cycling setpoints. Unless the service conditions indicate contamination, oil change is not required and standard filter driers can be used. Remember oil loss can occur during the recovery process. Check oil level after system has stabilized. Adjust if necessary. If leaks occur, you may recharge (top-off) without effecting system performance. As with other replacements, systems directly converted from R-12 may experience shrinkage of o-rings or gaskets, which could contribute to leakage.

If there are any questions concerning the application of R417C, contact TECH 2 TECH International support line at 1-866-433-TECH(8324)

R417C IS ANOTHER QUALITY PRODUCT FROM THE PRODUCERS OF R414B , R422C and R422B LEADING THE INDUSTRY IN REPLACEMENT REFRIGERANTS

## CONVERSION GUIDELINES

# R417C

- EPA SNAP LISTED - STATIONARY EQUIPMENT ONLY
- NOT FOR USE IN MOBILE APPLICATIONS
- NON-OZONE DEPLETING
- COMPATIBLE WITH ALL STANDARD REFRIGERANT OILS
- LOWER CONVERSION COSTS
- R-12 LIKE OPERATING CHARACTERISTICS
- BROAD APPLICATION RANGE
- LOW • MEDIUM • HIGH TEMPERATURES
- BACKED BY WARRANTY

**TECH<sub>2</sub>TECH**   
REFRIGERANT RELATED  
DIAGNOSTIC SUPPORT  
866-433-TECH (8324)

**ENVIRO**  
REFRIGERANTS

**ALLTEMP**   
www.alltemp.ca

# R417C

## CONVERSION GUIDELINES FOR R-12, 134a and 500 DX SYSTEMS

R417C is a non-ozone depleting blend, which can be used as a direct refrigerant replacement into existing systems that are still operating on R-12, 134a and 500. It is compatible with all standard ACR system lubricants, i.e. MO, AB, and POE oils.

### SYSTEM REQUIREMENTS

- 1) System must be designed for use with R-12, 134a and 500 free of leaks, and in sound operating condition.
- 2) R417C is designed for use in systems utilizing direct expansion metering, i.e. TXV, orifice, cap tube. Before using R417C in a flooded system consult TECH 2 TECH technical staff. R417C is not designed for use in mobile applications.
- 3) The system should be operating within its design capacity. Consult TECH 2 TECH before converting any system with pre-existing capacity problems.
- 4) The system should be charged with the proper type and amount of lubricant, as required by the original equipment and component manufacturers.

### NOTIFICATION TO USERS:

The information contained in this document is given in good faith based on our current knowledge. It is only an indication and should not be construed as an endorsement or guarantee of performance to any specific application and is in no way binding. We guarantee that our products comply with our sales specifications. This information is not to be used as a substitution for system analysis as to suitability. Users are responsible for compliance with local, state, and federal regulations for recovery and evacuation.

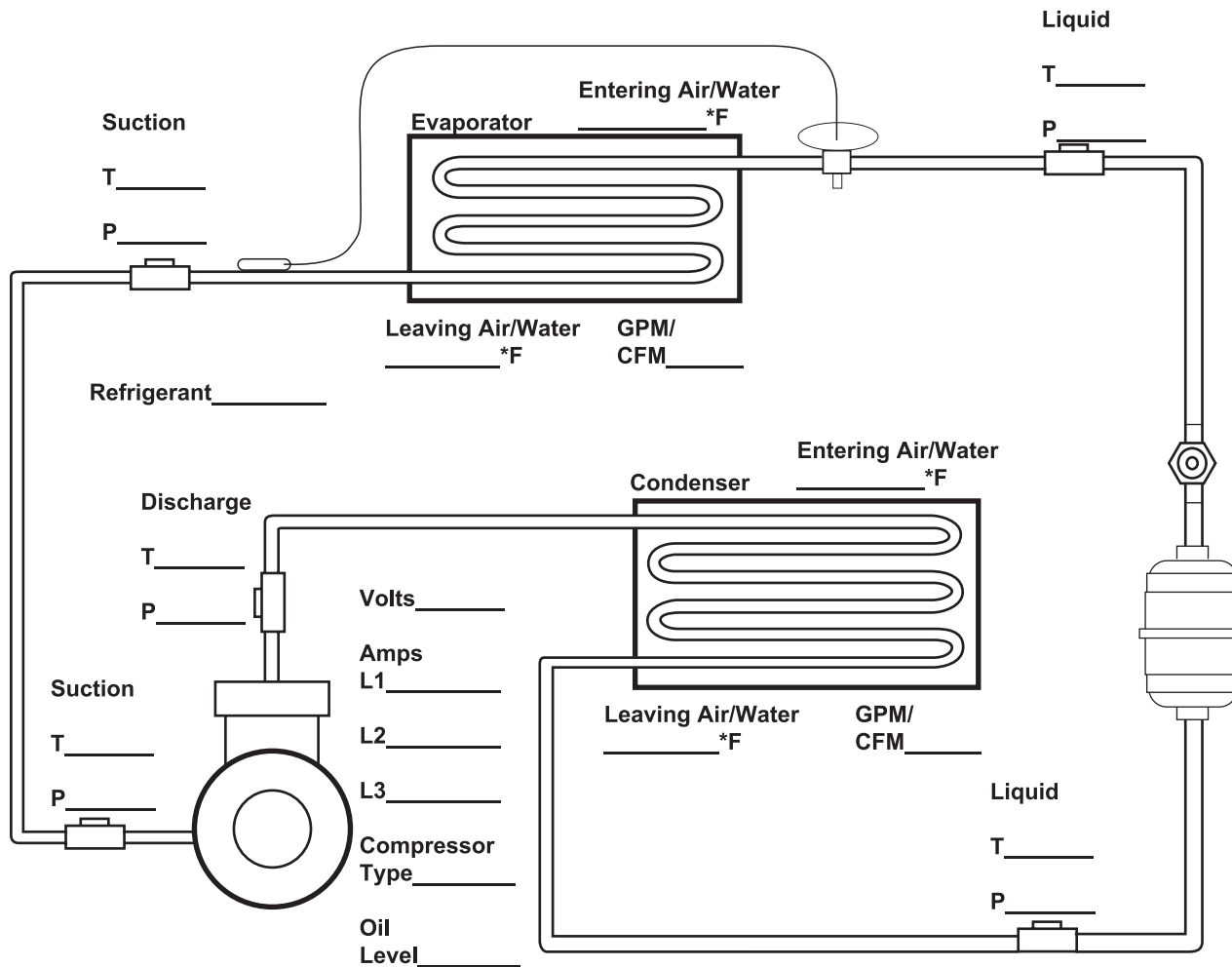

EVAPORATOR					
Dew (F)	(psig)	Dew (F)	(psig)	Dew (F)	(psig)
-20	0.2	10	15.7	40	41.7
-18	0.9	12	17.1	42	43.9
-16	1.8	14	18.5	44	46.2
-14	2.6	16	20.0	46	48.5
-12	3.5	18	21.5	48	50.9
-10	4.4	20	23.0	50	53.3
-8	5.4	22	24.7	52	55.9
-6	6.3	24	26.3	54	58.5
-4	7.4	26	28.1	56	61.1
-2	8.4	28	29.8	58	63.9
0	9.6	30	31.7	60	66.7
2	10.7	32	33.6		
4	11.9	34	35.5		
6	13.1	36	37.5		
8	14.4	38	39.6		

CONDENSER					
Bubble (F)	(psig)	Bubble (F)	(psig)	Bubble (F)	(psig)
80	107	102	155	122	209
82	111	104	160	124	215
84	115	106	165	126	221
86	119	108	170	128	227
88	123	110	175	130	234
90	127	112	180	132	240
92	132	114	186	134	247
94	136	116	191	136	254
96	141	118	197	138	261
98	145	120	203	140	268
100	150				

Conversion Data:	PRE	POST
Suction PSIG	_____	_____
Suction Temp	_____	_____
Discharge PSIG	_____	_____
Discharge Temp	_____	_____
Evap. Superheat	_____	_____
Comp. Superheat	_____	_____
Subcooling	_____	_____
Ambient Temp	_____	_____
Weight of Refrigerant	_____	_____
Comp. Oil Temp	_____	_____
Comp. Oil Level	_____	_____
Comp. Motor Amps	_____	_____
L1 _____	L2 _____	L3 _____